

THE WHARF STUDIOS LONDON



FILM, TELEVISION AND MEDIA PRODUCTION STUDIOS

Located in Barking, London, The Wharf is London's newest production facility and is "powered by MBS", the world's leading studio design, management and technical equipment company.

The private 10 acre Thames riverside campus includes six large sound stages, purpose-built and acoustically treated, with full supporting infrastructure, including production offices, workshops, drive-in access and ample parking.

With over 200,000 sqft of flexible creative space, The Wharf Studios London has been designed by industry professionals, for industry professionals.

The Wharf Studios London
8 River Road, Barking IG11 0JE



FILM • TELEVISION • COMMERCIALS • DRAMA • STILLS • VIDEO • REHEARSAL

THE WHARF STUDIOS LONDON

STUDIOS

The Wharf Studios, London - over 200,000 sqft of production facilities.

Incorporating six large acoustically treated stages, along with extensive office areas, dedicated workshops, dedicated hair & make-up, laundry plus an abundance of highly adaptable break out spaces, The Wharf Studios is the newest and most comprehensive, production campus, serving high-end film and TV, in the city of London.

- 10 acre self-contained, secure site
- 104,000 sqft of stage space; 6 clear-span sound stages
- 32,000 sqft of workshops
- 62,000 sqft production offices
- On-site restaurant/coffee shop
- Hair and make-up, wardrobe, green rooms, laundry, break-out spaces
- Excellent access in/out of London

THE WHARF HOUSE - OFFICES/COFFEE SHOP

GROUND FLOOR

Offices, open plan areas, rest rooms, kitchenettes, coffee shop and patio



FIRST FLOOR

Offices, open plan areas, rest rooms and kitchenettes

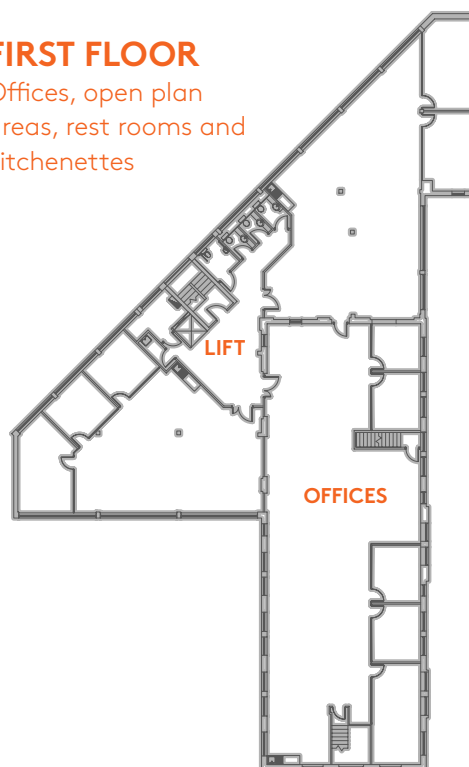

THE WHARF STUDIOS LONDON

SOUTH BUILDING

Stage 1

21,797 sqft/2025m²

Height: 46 ft/14m

Stage 2

21,937 sqft/2030m²

Height: 46ft/14m

Stage 3

16,576 sqft/1540m²

Height: 34 ft/10.3m

Stage 4

16,770 sqft/1557m²

Height: 34 ft/10.3m

Stage 5

21,850 sqft/2030m²

Height: 33 ft/10m

Facilities/Amenities

Acoustically treated
Drive in Access 5m x 5m
Column free/open span stages
Restrooms
Breakrooms
Production offices
Green Room
Workshops
Hair & Make Up
Wardrobe
Laundry

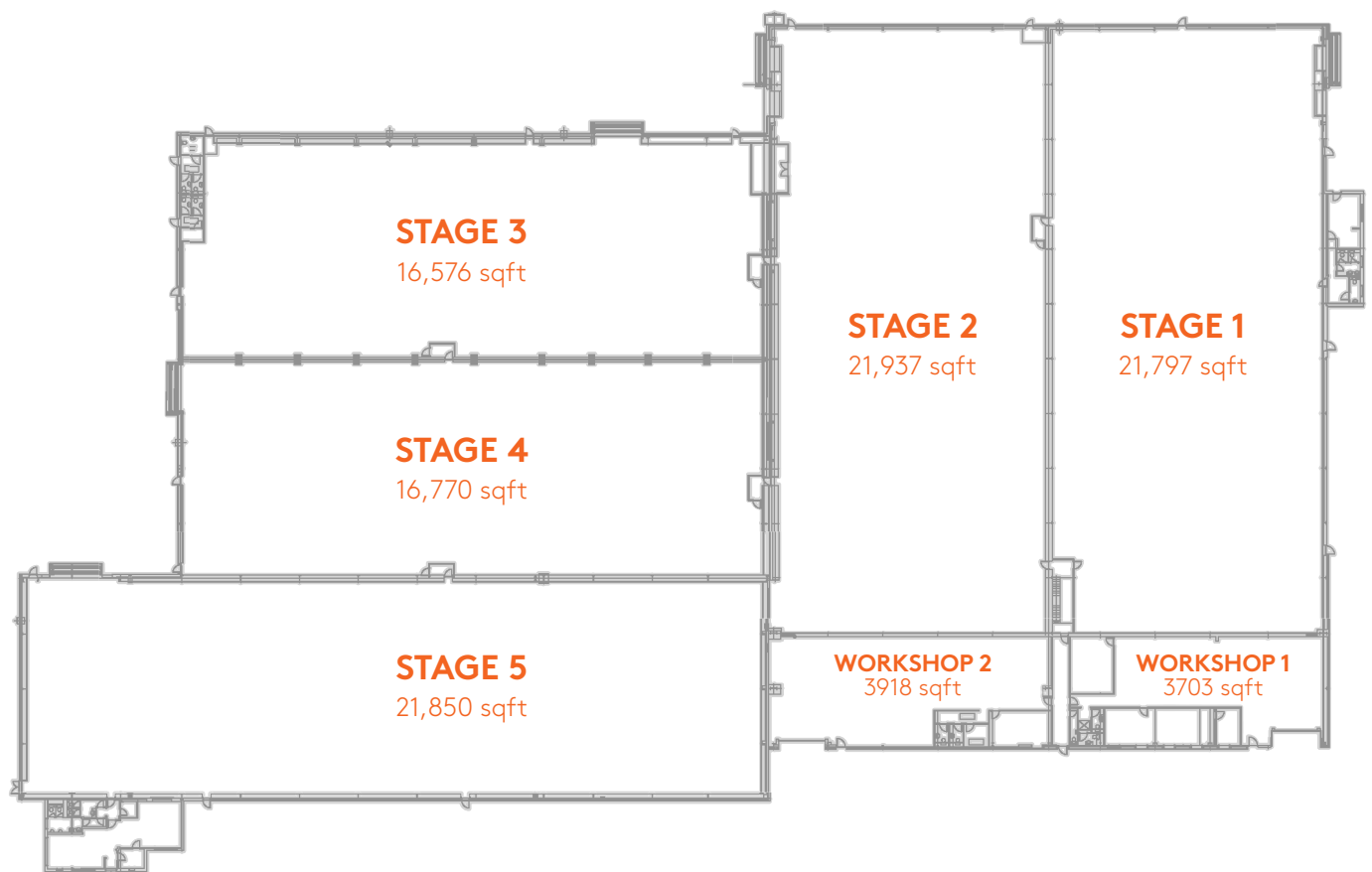

THE WHARF STUDIOS LONDON

NORTH BUILDING

Stage 6

7,276 sqft/676m²

Height 26 ft/8m

Workshop 3

15,142 sqft/1406m²

Workshop 4

9353 sqft/869m²

Workshop 5

2709 sqft/251m²

Facilities/Amenities

Acoustically treated

Drive in Access 5m x 5m

Column free/open span stages

Flexible Space

Restrooms

Breakrooms

Offices

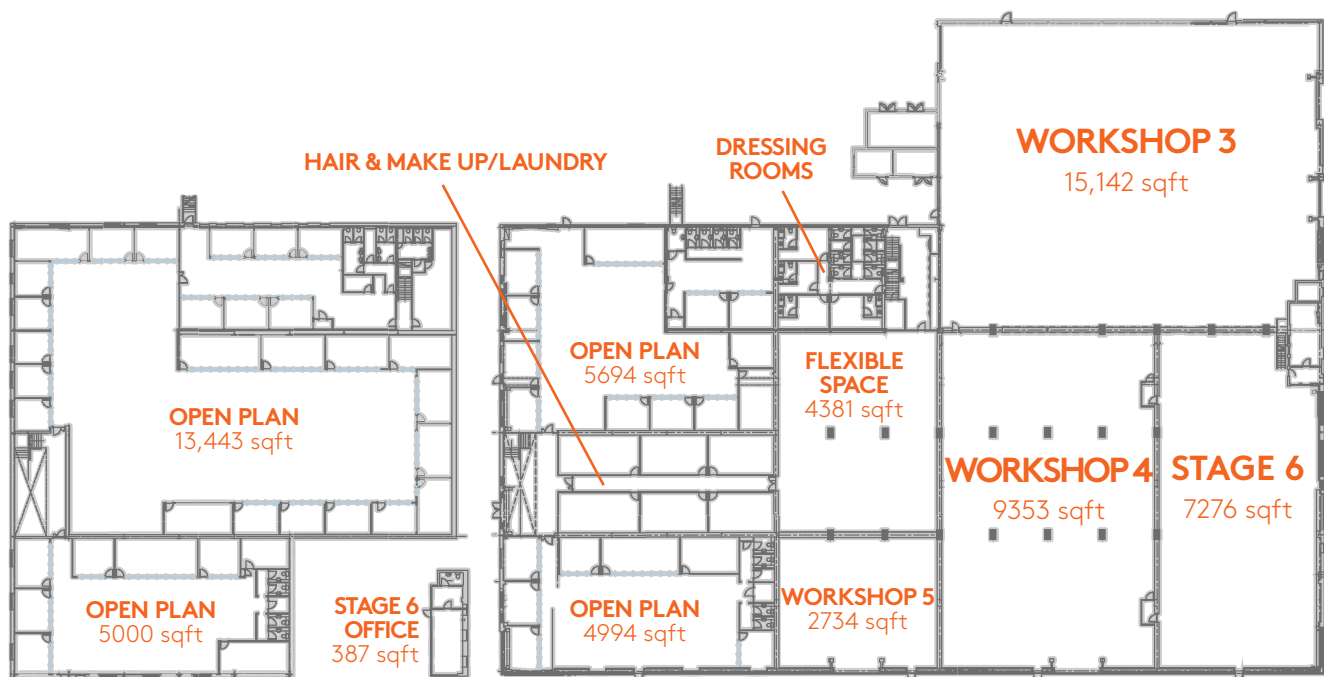

FIRST FLOOR
OFFICES

GROUND FLOOR
STAGE, OFFICES and
WORKSHOPS



THE WHARF STUDIOS LONDON

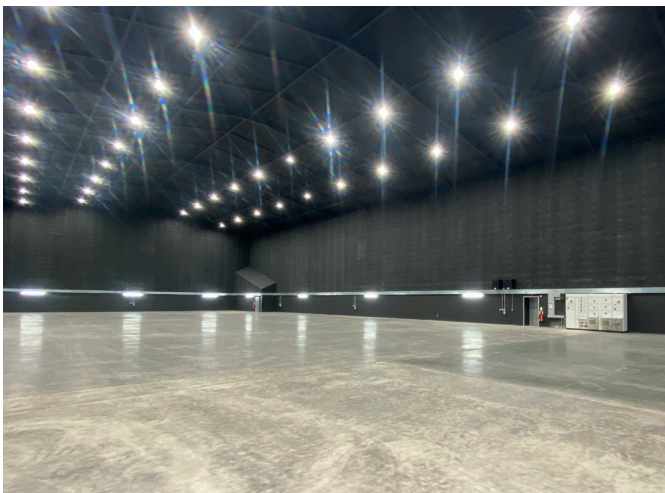
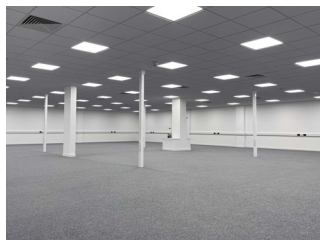
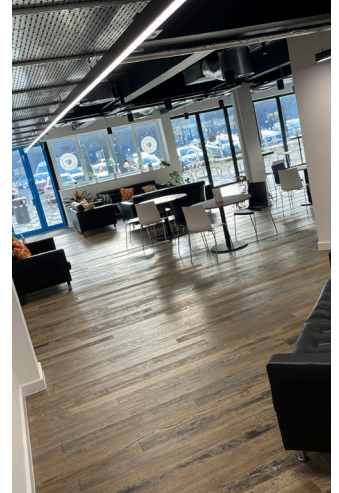

POWERED BY 

FILM • TELEVISION • COMMERCIALS • DRAMA • STILLS • VIDEO • REHEARSAL

THE WHARF STUDIOS LONDON

CABIN/OFFICES

Additional on-site cabins. Positioned adjacent to the parking area to the rear of the stages, the two storey, open plan cabins are ideal for use as additional or 'overflow' production offices. These self contained, secure units are heated and have private kitchenette, electrics and network points fitted.

CABIN A - GROUND FLOOR 968 sqft/90m²

CABIN B - FIRST FLOOR 32 sqft/3m²

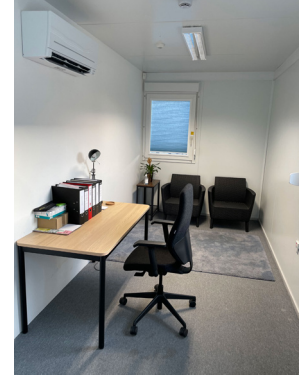
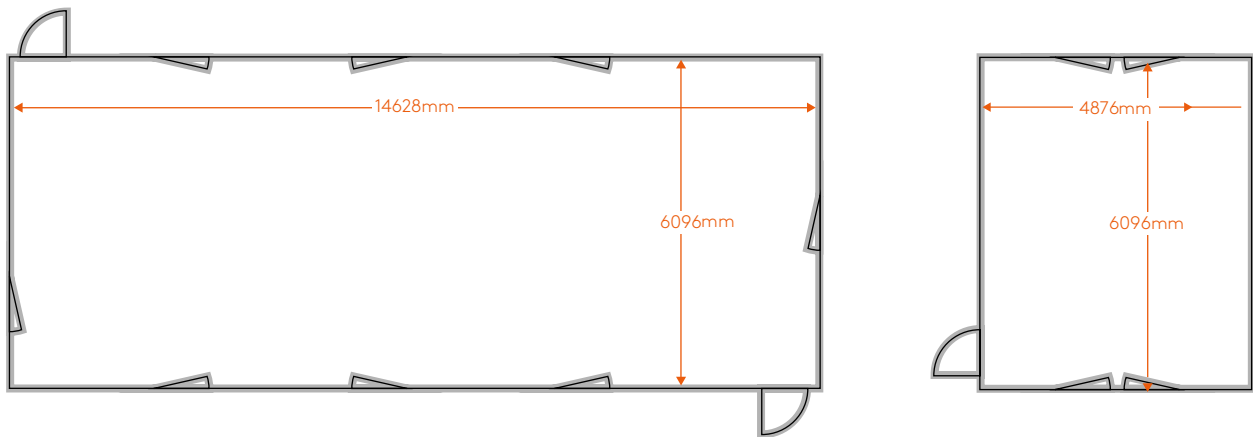

THE WHARF STUDIOS LONDON

LOCATION

The Wharf Studios : London

8 River Road, Barking Essex IG11 0JE

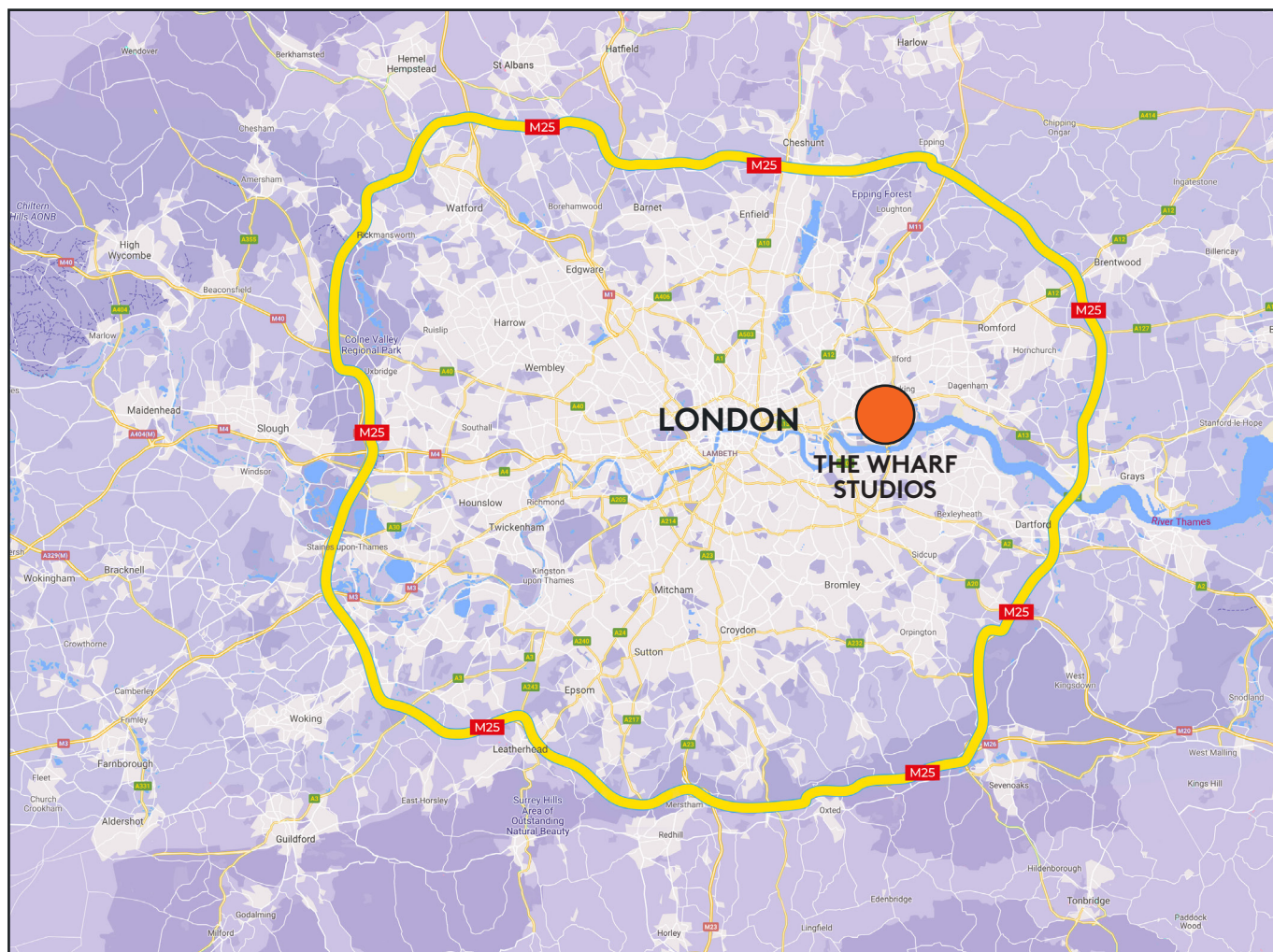

LOCATION - TRANSPORT LINKS

The London Borough of Barking & Dagenham (LBBB) is the UK's youngest and most culturally diverse borough. The area is well-suited to the creative industries, and it is more proximate to Soho and Central London, where visiting talent often prefers to stay, than most of the other filming facilities.

As London has more recently expanded easterly, nearby areas like Shoreditch and Hackney have become havens for young artists, production crew, media executives, and tech companies.

By Car

Only 5.9 miles and 11 mins drive from Canary Wharf in central London, with excellent road links to the M25 motorway.

By Train

Nearby Barking Station is served by the London Underground's District Line and Hammersmith & City Line, as well as the London Overground, and the c2c rail service into Fenchurch Street.

- 20 mins to Liverpool Street
- 37 mins to King's Cross
- 15 mins to London City Airport

Barking Riverside London Overground station connects passengers to central London in as little as 22 minutes and to Barking in 7 minutes

By Boat

Uber Boat by Thames Clippers provides riverboat service from Barking Riverside into Central London